

CREATING  
POWER  
SOLUTIONS

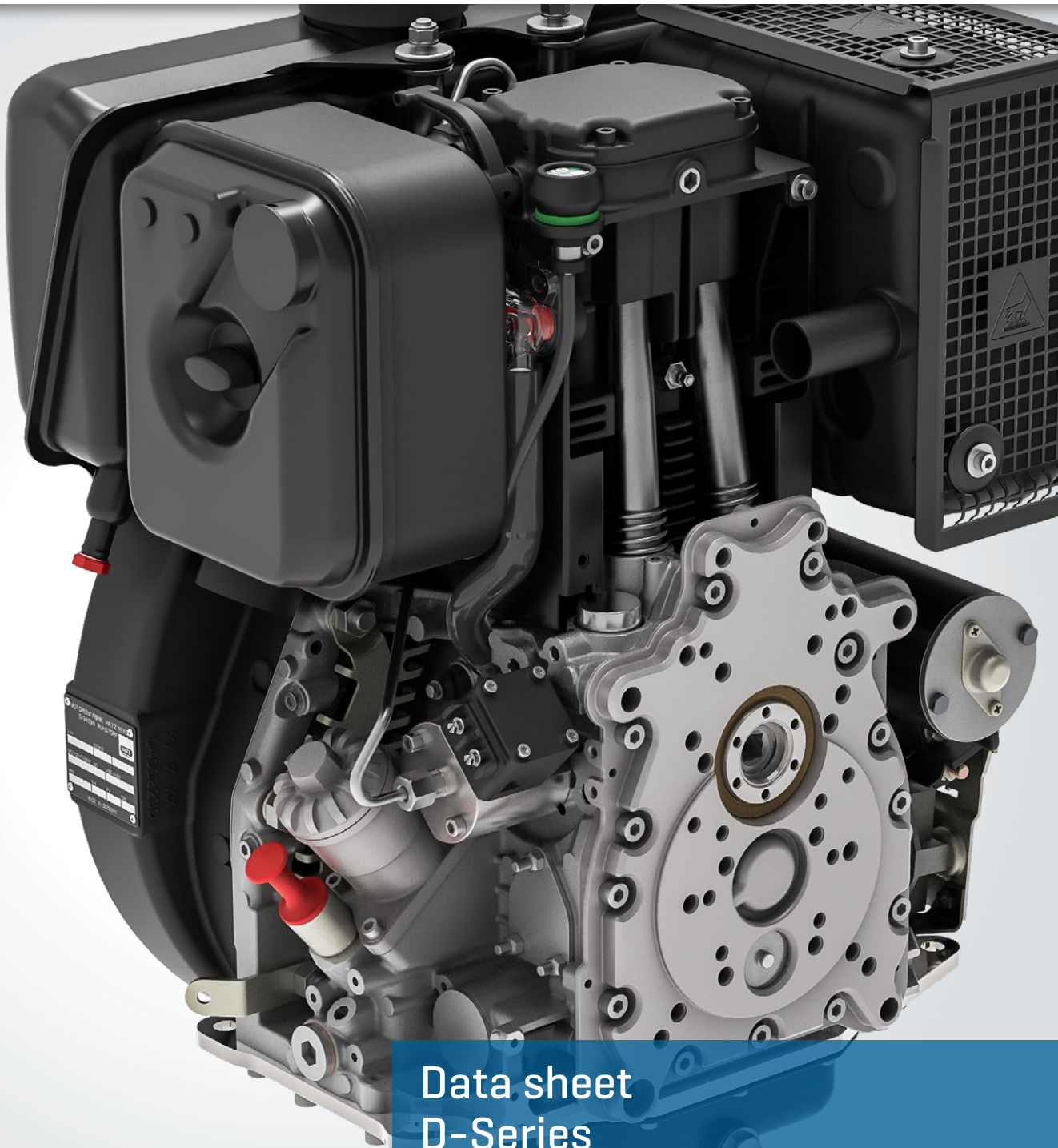

Data sheet  
D-Series  
Industrial Diesel Engines

Hatz Drive Solutions



**1D90E DPF with Diesel Particulate Filter**

Although not required by law, Hatz offers the 1D90E engine with an optional passive diesel particulate filter for EU Stage V for defined applications. This makes it possible to work in critical environments such as trenches.



**1D81C - Silent Pack**

For decades Hatz Silent Packs have been setting benchmarks for quiet and reliable diesel engines. Silent Pack is more than just an engine, it is a complete installation solution where the customer no longer has to take care of anything. Position, connect, start.

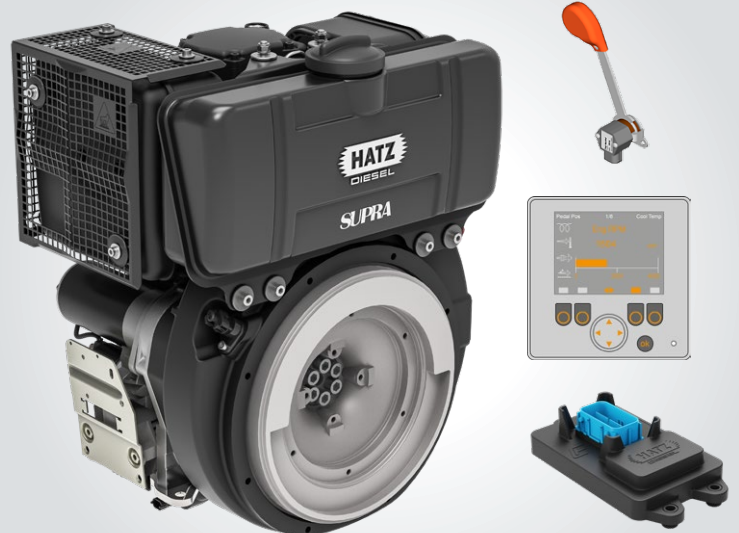

**First Full Electronic and Full Variable Speed Control < 19 kW**

The 1D90E being part of the E1 family can be controlled by with standard J1939 CAN protocols - thanks to the ECU. It is also possible to use CAN-Displays to monitor the engine performance.

# Hatz D-Series: The Single-Cylinder Diesel Engine with Revolutionary Engineering

As our customers can confirm, Hatz diesel engines are the most robust and durable in this market segment. Wherever they are installed makes no difference; whether at very low temperatures or in a tropical climate, the Hatz D-Series carries out its job reliably. With regular maintenance many thousands of hours are commonplace, using Hatz Genuine Spare Parts, of course.

## High performance and flexibility

The Hatz D-Series is best suited for challenging tasks. It is characterized by high performance and flexibility in particular. With 11.2 kilowatts, the Hatz 1D90 engine is the highest performance single-cylinder diesel engine in the world. The engines can be configured as required and in the basic version limited to the core engine only. With up to three different power take offs on a single engine, the Hatz D-Series provides more possibilities for the customization of a machine than any other engine on the market.

## Extremely quiet running

Compensation weight on the flywheel side crank arm as well as balance weights cast in the flywheel ensure the special quiet running of the Hatz D-Series. Optionally available counter-rotating balance shafts even ensure 100 percent first order counter balance.

## Single-cylinder for the digital future

The Hatz E1 technology controls the injection electronically. In the form of the 1D90E, it enters into a fruitful connection with the core engine of the D-Series, which has proven its excellence hundreds of thousands of times. This provides completely new possibilities in a digital world.

## Raising digital potentials

The engines can be linked to the Hatz Digital Solutions. These allow key information on machine operation to be integrated into fleet management, thereby enabling machine operators to make better decisions. Also possible: optimization of the machine disposition and maintenance,

localization and geofencing, and maximization of machine productivity.

## Environmental aspects

Even without legislation, Hatz D-Series engines have been produced and sold for many years in compliance with the strict US emission standard EPA Tier 4. Thus, the Hatz 1D90E meets both the North American requirements as well as EU Stage V. All D-Series engines also meet the European requirements.

## The Silent Pack

The Hatz D-Series is the first single-cylinder diesel engine series which can be equipped with an organically adapted, sound-insulated noise encapsulating housing, the Silent Pack. The Silent Pack reduces the radiated noise emission by up to 12 dezibels in a 7 meter radius.

The capsule consists of sheet metal construction with structure-borne sound insulation that is mounted on the engine. All control and service points are accessible from the outside. The sound suppressor is housed in a separate capsule over the flywheel. Due to the cooling air circulation, Silent Pack engines – like all other Hatz engines – can be used under virtually all climatic conditions.

## 1D90E DPF with diesel particulate filter

Although not required by law, Hatz offers the 1D90E engine with an optional passive diesel particulate filter for EU Stage V for defined applications. This makes it possible to work in critical environments such as trenches.

Sales area exhaust certificate	[rpm]	IFN Rating						IFN/ICFN Rating
		1D42	1D50	1D81	1D81C	1D90E	1D90	1D90V
US EPA T4f/CARB constant		–	–	–	–	3000	–	–
USA EPA T4f variable		–	–	–	–	3000	–	–
Europe EU V constant		1500, 1800, 3000	3000	1500, 1800, 3000	1500, 1800, 3000	1500, 3000	1500, 1800, 3000	1500, 3000
Europe EU V variable		2000–3200	2400–3200	1500–3000	1500–3000	3000	1500–3000	2300–3000
Less regulated		1500–3600	1500–3600	1500–3600	1500–3000	3000	1500–3000	

# Technical Data, Performance Table

Technical data		1D42	1D50	1D81	1D81C	1D90E	1D90	1D90V	
Type	Air-cooled 4 stroke diesel engine								
Cylinder	1								
Direct injection	mechanical	mechanical	mechanical	mechanical	electronical	mechanical	mechanical	mechanical	
Position of crank shaft	horizontal							vertical	
Bore x stroke [mm / in]	90 x 70 / 3.54 x 2.76	97 x 70 / 3.82 x 2.76	100 x 85 / 3.94 x 3.35	100 x 85 / 3.94 x 3.35		104 x 85 / 4.09 x 3.35		104 x 85 / 4.09 x 3.35	
Displacement [l / cu in]	0.445 / 27.2	0.517 / 31.5	0.667 / 40.7	0.667 / 40.7		0.722 / 44.0		0.722 / 44.0	
Average piston speed @ 3000 rpm [m/s / ft/min]	8.5 / 1673								
Compression ratio	21.5 : 1							20.5 : 1	
Lubrication oil consumption, related to full load	approx. 1 % of fuel consumption								
Oil filling	max. [l / US qts]	1.2 / 1.27	1.5 / 1.59	1.9 / 2.0			1.6 / 1.7		
	min. [l / US qts]	0.8 / 0.85	1.0 / 1.06	1.0 / 1.06			0.9 / 0.95		
Lowest idle speed [rpm]	approx. 800								
Speed control	Static speed droop @ 3000 rpm	approx. 5%			configurable		approx. 5%		
	Control method	mechanical			CAN J1939, multi stage switch, analog		mechanical		
Installation information	Amount of combustion air @ 3000 rpm approx. [kg/h / cfm] <sup>1</sup>	47.7 / 23.3	56.4 / 27.6	72.3 / 35		79.5 / 39			
	Amount of cooling air @ 3000 rpm approx. [kg/h / cfm] <sup>1</sup>	325.1 / 159	397.4 / 195	780.3 / 380	606.9 / 297	780.3 / 380		1083.7 / 530	
	Mass moment of inertia J <sub>engine</sub> [kgm <sup>2</sup> / lb ft <sup>2</sup> ]	Standard flywheel	0.24 / 5.67	0.41 / 9.7	0.51 / 12.05				
		Heavy flywheel	0.28 / 7.08	–	0.63 / 14.9				
	Starter [V]	12 [2.0 kW / 2.7 hp]   24 [3.0 kW / 4.0 hp]							
Alternator charging current @ 3000/1500 rpm [A]	approx. 9/4 [14 V]   approx. 5/2 [28 V]			approx. 16/5 [14 V]   approx. 9/4 [28 V]					
Battery capacity min. / max. [Ah]	45 / 88 [12 V]   36 / 55 [24 V]								
Dimensions	Engine with crankhandle start [kg / lb]	71 / 156.5	80 / 176.4	97 / 213.8	118 / 260.0	–	98 / 216.0	–	
	Engine with electric start [kg / lb]	78 / 172.0	83 / 183.0	105 / 231.4	126 / 277.7	107 / 235.9	106 / 233.6	106 / 233.6	
	L x W x H [mm / in]	357 x 432 x 500 / 14.1 x 17.0 x 19.7	357 x 432 x 512 / 14.1 x 17.0 x 20.2	373 x 472 x 599 / 14.7 x 18.6 x 23.6	505 x 523 x 591 / 19.9 x 20.6 x 23.2	373 x 505 x 599 / 14.7 x 19.9 x 23.6	373 x 472 x 599 / 14.7 x 18.6 x 23.6	583 x 486 x 429 / 23.0 x 19.1 x 16.9	
Engine output [kW / hp]	[rpm]	1D42	1D50	1D81	1D81C	1D90E <sup>2</sup>	1D90	1D90V	
Blocked ISO brake horsepower (IFN) for intermittent loading according to ISO 3046-1. For variable speed.	3200	6.8 / 9.1	7.5 / 10.1	–	–	–	–	–	
	3000	6.6 / 8.9	7.5 / 10.1	10.0 / 13.4	9.5 / 12.7	10.5 / 14.1	11.0 / 14.8	–	
	2800	6.4 / 8.6	7.2 / 9.7	9.6 / 12.9	9.1 / 12.2	10.1 / 13.4	10.6 / 14.2	–	
	2600	6.1 / 8.2	6.8 / 9.1	9.2 / 12.3	8.7 / 11.7	9.6 / 12.8	10.1 / 13.5	–	
	2300	5.4 / 7.2	–	6.3 / 8.4	8.0 / 10.7	8.8 / 11.8	9.2 / 12.3	–	
	2000	4.7 / 6.3	–	7.5 / 10.1	7.1 / 9.5	7.7 / 10.3	8.1 / 10.9	–	
	1800	–	–	6.8 / 9.1	6.5 / 8.7	7.1 / 9.5	7.3 / 9.8	–	
	1500	–	–	5.5 / 7.4	5.4 / 7.2	5.7 / 7.6	6.1 / 8.2	–	
Blocked ISO brake horsepower (IFN) for intermittent loading according to ISO 3046-1. For constant speed.	3000	6.6 / 8.9	7.5 / 10.1	10.0 / 13.4	9.5 / 12.7	10.5 / 14.1	11.0 / 14.8	–	
	1800	4.1 / 5.5	–	6.8 / 9.1	6.5 / 8.7	–	7.3 / 9.8	–	
	1500	3.3 / 4.4	–	5.5 / 7.4	5.4 / 7.2	5.7 / 7.6	6.1 / 8.2	–	
Blocked ISO brake horsepower (IFN) for intermittent loading according to ISO 3046-1. For variable speed. Less regulated markets	3600	7.0 / 9.4	7.5 / 10.1	10.1 / 13.5	–	–	–	–	
	3000	6.6 / 8.9	7.5 / 10.1	10.1 / 13.5	9.6 / 12.9	10.5 / 14.1	11.2 / 15.0	–	
	2800	6.4 / 8.6	7.2 / 9.7	9.7 / 13.0	9.2 / 12.3	10.1 / 13.4	10.7 / 14.3	–	
	2600	6.1 / 8.2	6.8 / 9.1	9.3 / 12.5	8.8 / 11.8	9.6 / 12.8	10.3 / 13.8	–	
	2300	5.4 / 7.2	6.0 / 8.0	8.4 / 11.3	8.1 / 10.9	8.8 / 11.8	9.5 / 12.7	–	
	2000	4.7 / 6.3	5.2 / 7.0	7.6 / 10.2	7.1 / 9.5	7.7 / 10.3	8.4 / 11.3	–	
	1800	4.1 / 5.5	4.6 / 6.2	6.8 / 9.1	6.5 / 8.7	7.1 / 9.5	7.6 / 10.2	–	
	1500	3.3 / 4.4	3.7 / 5.0	5.5 / 7.4	5.4 / 7.2	5.7 / 7.6	6.4 / 8.6	–	

<sup>1</sup> For other speeds, there is a linear reduction in the air requirement. <sup>2</sup> Power ratings include generator power

# Maximum Power Output, Torque and Fuel Consumption

## 1D42

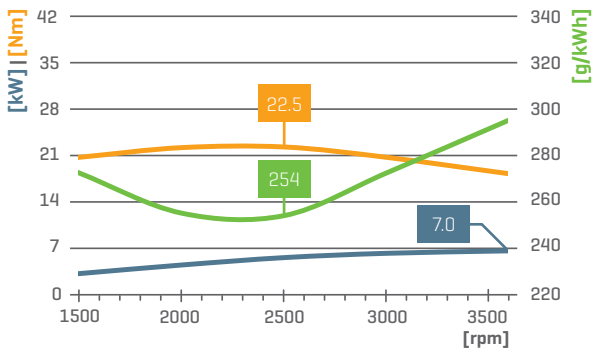

## 1D50

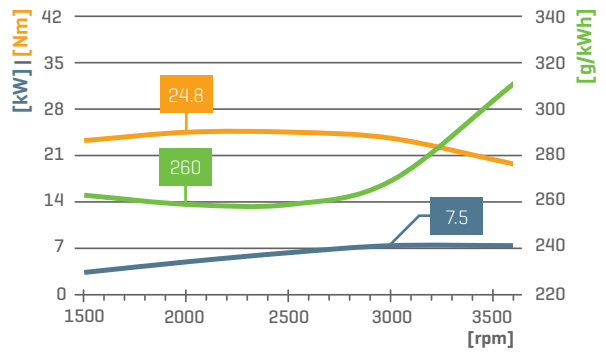

## 1D81

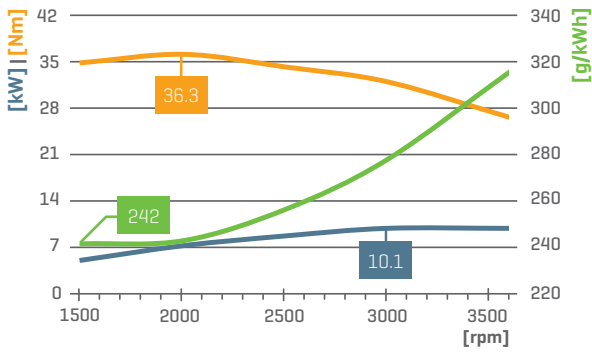

## 1D81C

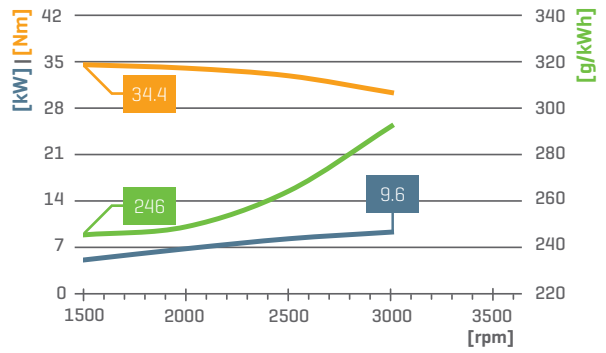

## 1D90E<sup>2</sup>

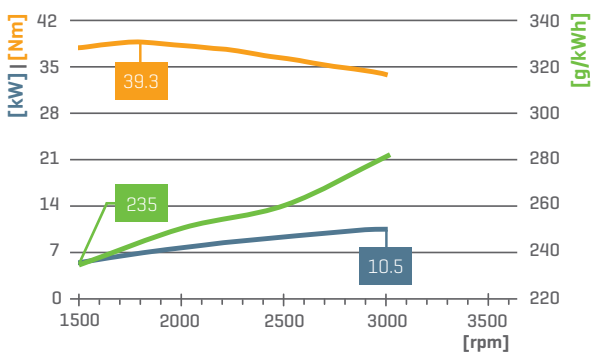

## 1D90 | 1D90V

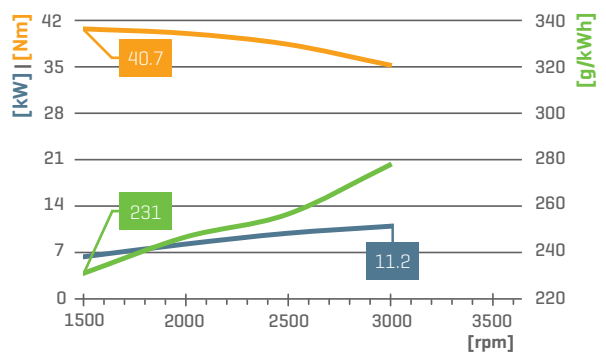

### Power ratings

Power ratings refer to standard reference conditions of ISO 3046-1 (IFN):

+ 25 °C (77 °F), 100 kPa, relative humidity 30 %. The specified power is reached during the running-in period, and can be 5 % less on delivery. Power reduction acc. to ISO 3046-1.

Standard values: More than 100 m above sea level approx. 1 % per 100 m, above 25 °C (77 °F) approx. 4 % per 10 °C (50 °F).

The power taken from the alternator also has to be added to the power calculation.

# Maintenance and Operating Points

1D42 | 1D50 | 1D81 | 1D90E | 1D90

1D81C

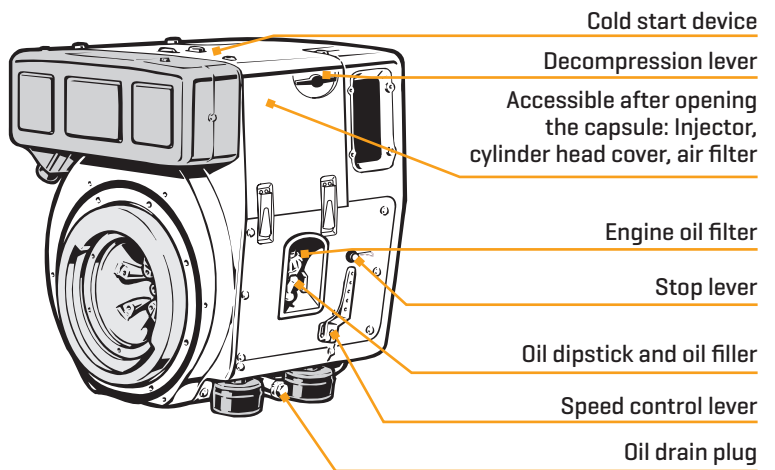
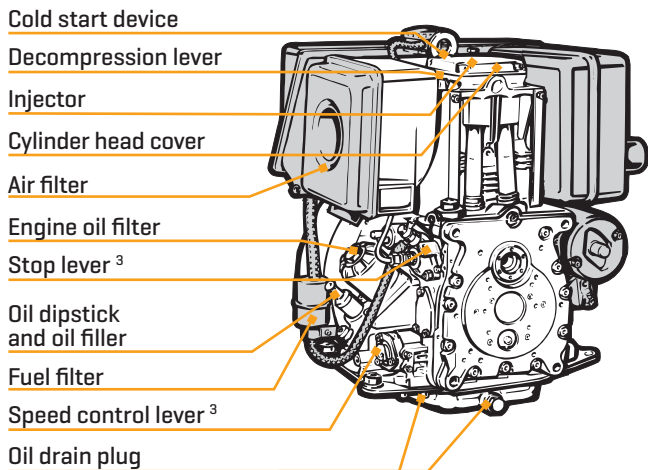

## 1D90V

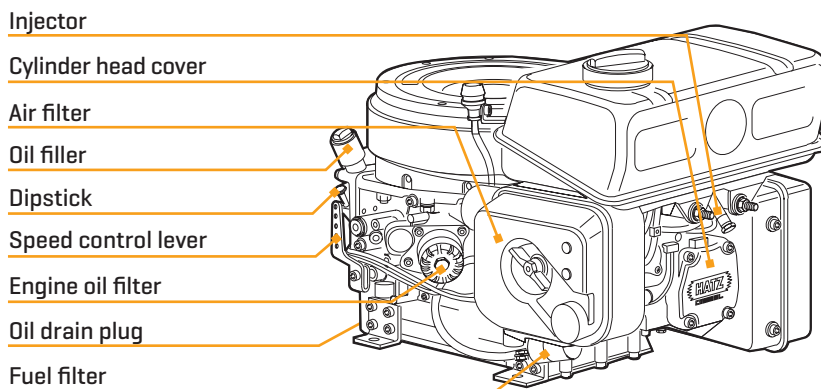

## Power-Take-off Points

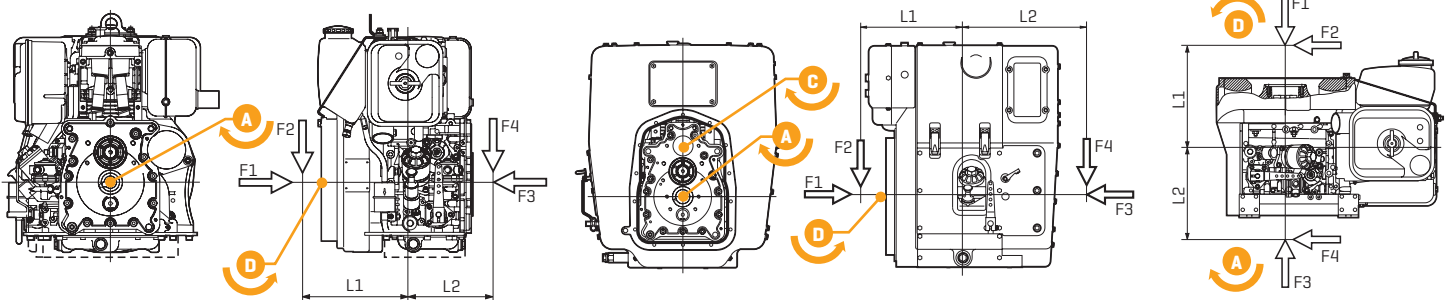

Power take off		1D42	1D50	1D81	1D81C	1D90E	1D90	1D90V
Transfer-able torque	A				100 %			
	C		not available		21.5 Nm / 15.9 lb-ft [6.8 kW / 9.1 hp @ 3000 rpm]			not available
	D				100 %			
Permissible load	F1					2250 N		
	F2		$F2 = \frac{261\,000}{L1 \text{ [mm / in]} - 42 / 1.65} \text{ [N]}$			$F2 = \frac{477\,000}{L1 \text{ [mm / in]} - 50.5 / 1.98} \text{ [N]}$		
	F3					1350 N		
	F4 <sup>a</sup>		$F4 = \frac{67\,500}{L2 \text{ [mm / in]} - 128 / 5.04} \text{ [N]}$			$F4 = \frac{67\,500}{L2 \text{ [mm / in]} - 134 / 5.28} \text{ [N]}$		

<sup>3</sup> Only for mechanically controlled engine types <sup>a</sup> If belt tension is upwards, outboard bearing is necessary.

# Dimensions [mm / in] and Inclinations<sup>5</sup> [°]

Spread at box dimensions ± 3 millimeters due to tolerance.  
 Drawings with detail and connection dimensions as PDF and DXF  
 can be found at [www.hatz.com](http://www.hatz.com).

**1D42  
1D50**

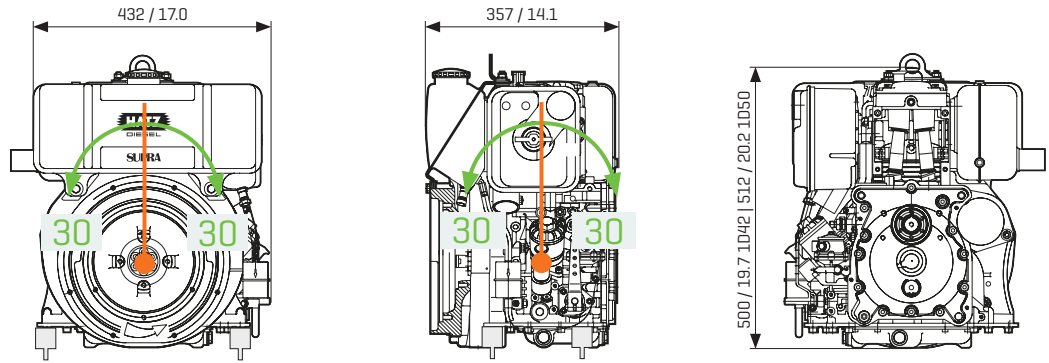

**1D81  
1D90E  
1D90**

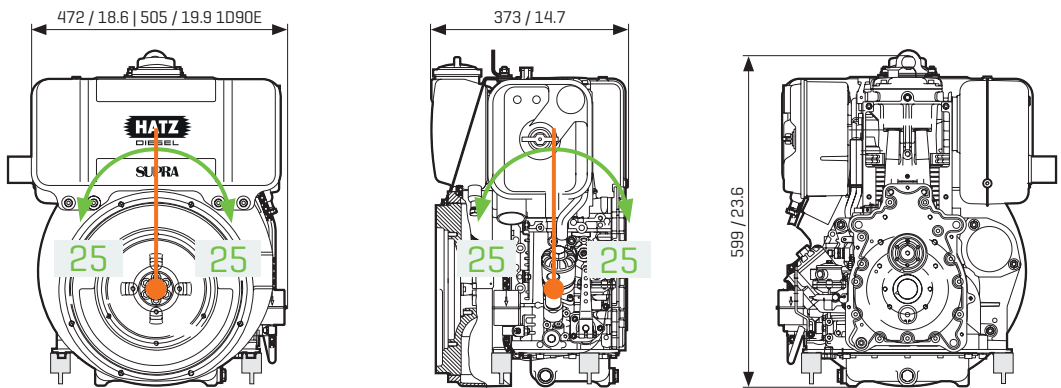

**1D81C**

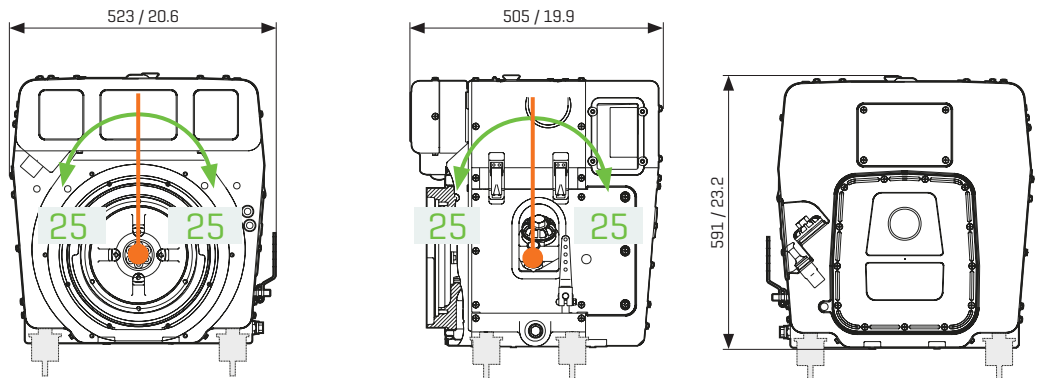

**1D90V**

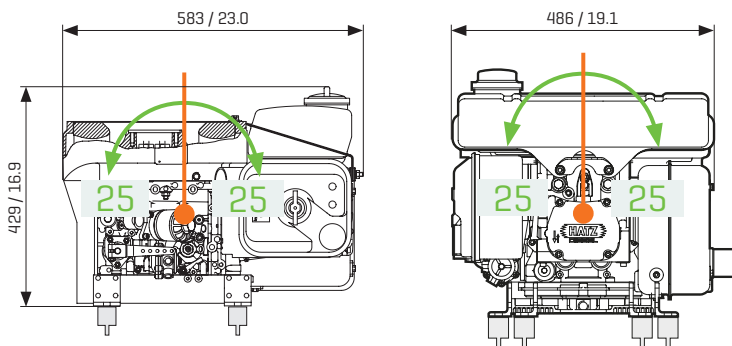

<sup>5</sup>Maximum permanent inclined positions

Motorenfabrik Hatz GmbH & Co. KG  
Ernst-Hatz-Str. 16  
94099 Ruhstorf a. d. Rott  
Germany  
Phone +49 8531 319-0  
marketing@hatz.com  
hatz.com



**CREATING  
POWER  
SOLUTIONS**

70257171 EN 10.22 Printed in Germany  
We reserve the right to make all changes  
that serve technical development.