

CREATING  
POWER  
SOLUTIONS

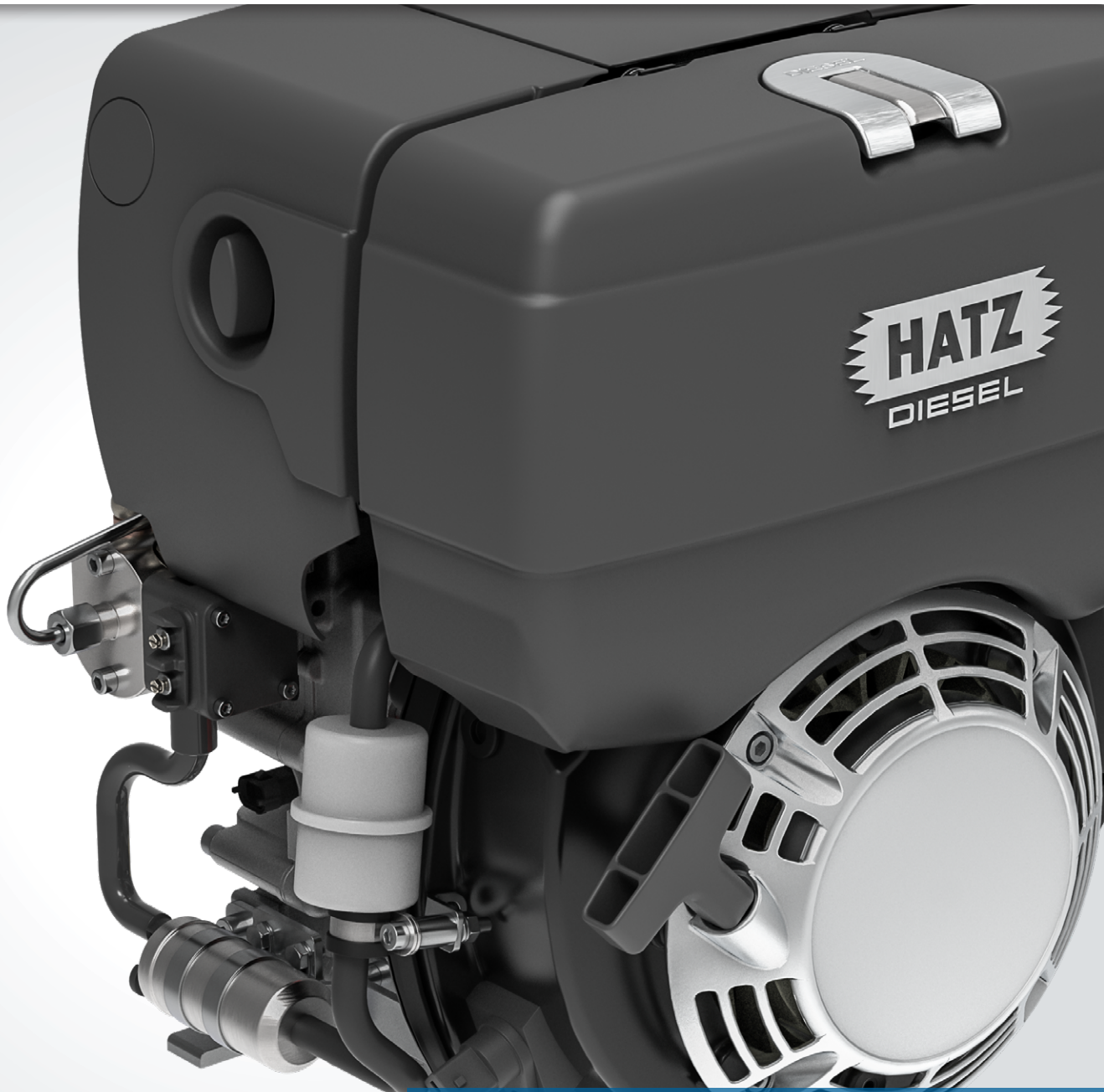

Data Sheet  
B-Series  
Industrial Diesel Engines

Hatz Drive Solutions

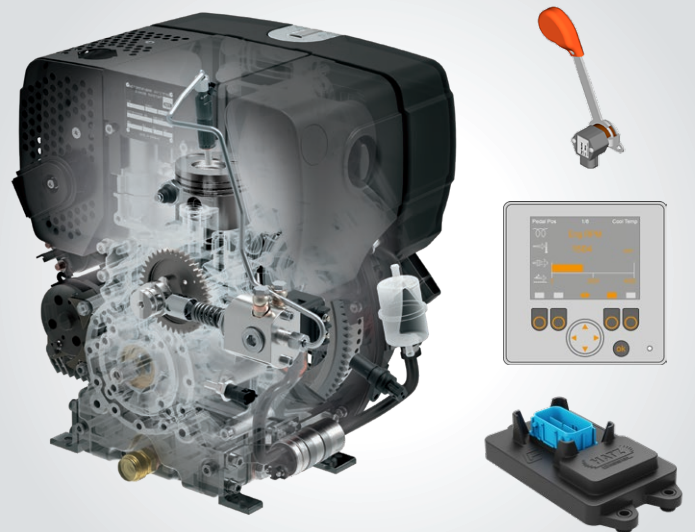

**1B30, 1B40, 1B50 Silent**

Depending on the engine type the already low noise level can be significantly reduced further, by 2 to 4 decibel [A], by an optional silent noise package, decreased power, and speed. This is possible thanks to optimisations in the area of intake and exhaust components.

**First Full Electronic and Full Variable Speed Control < 19 kW**

The models 1B30E, 1B30VE and 1B50E being part of the E1 family can be controlled with standard J1939 CAN protocols - thanks to the ECU controlling the engine. It is also possible to use CAN-Displays to monitor the engine performance.

# Hatz B-Series: Flexible Solution for All Areas

The Hatz B-Series scores high marks in mobile and stationary operations with compact installation dimensions and for all applications with a power requirement up to 8 kilowatts due to its low weight. With its robustness and longevity, the series sets standards in the market. Regardless of whether on vibration plates or in the inhospitable environment of the Antarctic, the Hatz B-Series has been tried and tested a hundred thousand times in harsh surroundings.

## From a mechanical masterpiece to the smartengine

The Single Cam System patented by Hatz essentially determines the very short overall length of the mechanically controlled engines. The injection pump and the valves are operated by a single cam and rocker arms. The Hatz E1 technology, on the other hand, controls the injection electronically. It enters into a fruitful relationship with the core engine of the B-Series, which has proven its excellence hundreds of thousands of times. And thus creates completely new possibilities.

## Raising digital potentials

The engines can be linked to the Hatz Digital Solutions. These allow key information on machine operation to be integrated into fleet management, thereby enabling machine operators to make better decisions. Also possible: optimization of the machine disposition and maintenance, localization and geofencing, and maximization of machine productivity.

## Environmental aspects

All B series engines have been designed for sustainability and environmental compatibility and undergo continuous development. For many years now, all engines in this series have been produced and sold in compliance with the regulations of the strict US emission standard EPA Tier 4, and this design is also exported to countries where exhaust emission limits are not stipulated. The E1 models fulfill all requirements of EPA Tier 4 final and are the only drive solution that offers variable engine speed.

## One power train – many variants

Thanks to the intelligent design of the engines, it is possible to offer various displacements based on the same power train. For the customer, this provides many options for making the best possible use of the existing space on a machine. Additionally this saves both time and money for the development and construction of entire machinery series.

## Optional silent noise package

Depending on the engine type the current low noise level can be significantly reduced further, by up to 4 decibels [A], by a silent noise package. This is possible thanks to optimisations in the area of intake and exhaust components.

## Awards

The engines of the E1 family won the Diesel Progress Award 2019 for the achievement of the year for the development of the ground breaking engine technology. In 2020, the fiPMG products which are based on the 1B30E, 1B30VE and 1B50E won the Diesel Progress Award for New Power Technology of the Year.

## 1B50E DPF with diesel particulate filter

Although not required by law, Hatz offers the 1B50E engine with an optional passive diesel particulate filter for EU Stage V for defined applications. This makes it possible to work in critical environments such as trenches.

Sales area Exhaust certificate	[rpm]	IFN Rating F/IFN/ICFN Rating						
		1B20	1B30E	1B30	1B30VE	1B40	1B50E	1B50
US EPA T4f/CARB constant		–	3000, 3600	–	3100	–	1800, 3000, 3600	–
US EPA T4f variable		–	3000, 3600	–	3100	–	3000, 3600	–
Europe EU V constant		3000, 3600	3000, 3600	2950–3000, 3600	3100	3000, 3600	1800, 3000, 3600	–
Europe EU V variable		2700–3350	3000, 3600	2000–3600	3100	2250–3600	3000, 3600	2500–3600
Less regulated		1500–3600	3000, 3600	1500–3600	3100	1500–3600	3000, 3600	1500–3600

# Technical Data, Performance Table

Technical data		1B20	1B30E <sup>1</sup>	1B30	1B30VE <sup>1</sup>	1B40	1B50E <sup>1</sup>	1B50
Type	Air cooled 4-stroke diesel engine							
Cylinder	1							
Direct injection	mechanical	electronical	mechanical	electronical	mechanical	electronical	mechanical	
Position of crank shaft	horizontal	horizontal		vertical	horizontal	horizontal		
Bore x stroke [mm / in]	69 x 65 / 2.72 x 2.56	80 x 69 / 3.15 x 2.72		80 x 69 / 3.15 x 2.72	88 x 76 / 3.46 x 2.99	93 x 76 / 3.66 x 2.99		
Displacement [l / cu in]	0.243 / 14.83	0.347 / 21.18		0.347 / 21.18	0.462 / 28.19	0.517 / 31.55		
Mean piston speed @ 3000 rpm [m/s / ft/min]	6.5 / 1279.53	6.9 / 1358.27		6.9 / 1358.27	7.6 / 1496.06	7.6 / 1496.06		
Compression ratio	22:1	21.5:1		21.5:1	20.5:1	20.5:1		
Lubrication oil consumption, related to full load	max. 1% of fuel consumption							
Lubrication oil capacity	max. [l / US qts]	0.9 / 0.951	1.2 / 1.27	1.1 / 1.162	1.2 / 1.27	1.5 / 1.528	1.6 / 1.69	1.5 / 1.528
	min. [l / US qts]	0.4 / 0.423	0.7 / 0.74	0.6 / 0.634	0.7 / 0.74	0.7 / 0.739	0.8 / 0.85	0.7 / 0.739
Speed control	Lowest idle speed [rpm]	approx. 1000			approx. 800			
	Static speed droop @ 3000 rpm	approx. 5%	configurable	approx. 5%	configurable	approx. 5%	configurable	approx. 5%
	Control method	mechanical	CAN J1939, multi stage switch, analog	mechanical	CAN J1939, multi stage switch, analog	mechanical	CAN J1939, multi stage switch, analog	mechanical
Installation Data	Combustion air required @ 3000 rpm approx. [kg/h / cfm] <sup>2</sup>	25.2 / 12.3	37.8 / 18.5		49.8 / 24.3		56.4 / 27.6	
	Cooling air required @ 3000 rpm approx. [kg/h / cfm] <sup>2</sup>	306 / 150	432 / 210		528 / 258		552 / 270	
	Starter [V]	12 [1.0 kW / 1.3 hp]   24 [1.6 kW / 2.1 hp]						
	Alternator charging current @ 3000 / 1500 rpm [A]	14 / 7 [14 V]   7 / 4 [28 V]						
Battery capacity min. / max. [Ah]	36 / 55 [12 V]   24 / 44 [24 V]							
Dimensions	Engine with recoil start [kg / lb]	28.0 / 61.7	–	35.0 / 77.2	–	48.0 / 105.8	–	51.2 / 112.9
	Engine with electric start [kg / lb]	32.8 / 72.3	40.8 / 90.0	39.8 / 87.7	42.8 / 94.4	53.3 / 117.5	57.5 / 126.8	56.5 / 124.6
	L x W x H [mm / in]	292 x 367 x 401 / 11.5 x 14.4 x 15.8	322 x 411 x 431 / 12.7 x 16.2 x 17.0	322 x 404 x 431 / 12.7 x 15.9 x 17.0	398 x 432 x 385 / 15.7 x 17.0 x 15.2	334 x 412 x 480 / 13.1 x 16.2 x 18.9	334 x 438 x 480 / 13.1 x 17.2 x 18.9	334 x 412 x 480 / 13.1 x 16.2 x 18.9

Engine output max. [kW / hp]	[rpm]	1B20	1B30E <sup>1,4</sup>	1B30	1B30VE <sup>1,4</sup>	1B40	1B50E <sup>1,4</sup>	1B50
Blocked ISO brake horsepower (IFN) for intermittent loading according to ISO 3046-1. For variable speed.	3600	–	4.5 / 6.0	5.0 / 6.7	–	7.3 / 9.8	7.9 / 10.6 8.1 / 10.9 <sup>3</sup>	7.9 / 10.6
	3000	3.1 / 4.2	4.1 / 5.6	4.6 / 6.2	4.1 / 5.6	6.8 / 9.1	7.6 / 10.2	7.6 / 10.2
	2800	2.9 / 3.9	4.0 / 5.3	4.5 / 6.0	4.0 / 5.3	6.6 / 8.9	7.3 / 9.8	7.3 / 9.8
	2600	–	3.8 / 5.1	4.2 / 5.6	3.8 / 5.1	6.3 / 8.4	6.9 / 9.3	6.9 / 9.3
	2300	–	3.5 / 4.7	3.9 / 5.2	3.5 / 4.7	5.7 / 7.6	6.2 / 8.3	–
	2000	–	3.1 / 4.1	3.4 / 4.6	3.1 / 4.1	–	5.3 / 7.1	–
Blocked ISO brake horsepower (IFN) for intermittent loading according to ISO 3046-1. For constant speed.	3600	3.4 / 4.6	4.5 / 6.0	5.0 / 6.7	–	7.3 / 9.8	7.9 / 10.6 8.1 / 10.9 <sup>3</sup>	7.9 / 10.6
	3100	–	–	–	4.2 / 5.6	–	–	–
	3000	3.1 / 4.2	4.1 / 5.5	4.6 / 6.2	4.1 / 5.5	6.8 / 9.1	7.6 / 10.2	7.6 / 10.2
	1800	–	–	–	–	–	4.7 / 6.3	–
	1500	–	–	–	–	–	–	–
Blocked ISO brake horsepower (IFN) for intermittent loading according to ISO 3046-1. For variable speed. Less regulated markets	3600	3.4 / 4.6	4.5 / 6.0	5.0 / 6.7	–	7.3 / 9.8	7.9 / 10.6 8.1 / 10.9 <sup>3</sup>	7.9 / 10.6
	3000	3.1 / 4.2	4.1 / 5.6	4.6 / 6.2	4.1 / 5.6	6.8 / 9.1	7.6 / 10.2	7.6 / 10.2
	2800	2.9 / 3.9	4.0 / 5.3	4.5 / 6.0	4.0 / 5.3	6.6 / 8.9	7.3 / 9.8	7.3 / 9.8
	2600	2.8 / 3.8	3.8 / 5.1	4.2 / 5.6	3.8 / 5.1	6.3 / 8.4	6.9 / 9.3	6.9 / 9.3
	2300	2.5 / 3.4	3.5 / 4.7	3.9 / 5.2	3.5 / 4.7	5.7 / 7.6	6.2 / 8.3	6.2 / 8.3
	2000	2.1 / 2.8	3.1 / 4.1	3.4 / 4.6	3.1 / 4.1	4.9 / 6.6	5.3 / 7.1	5.3 / 7.1
	1800	1.9 / 2.5	2.7 / 3.6	3.0 / 4.0	2.7 / 3.6	4.4 / 5.9	4.7 / 6.3	4.7 / 6.3
	1500	1.5 / 2.0	2.1 / 2.8	2.3 / 3.1	2.1 / 2.8	3.5 / 4.7	3.9 / 5.2	3.9 / 5.2

<sup>1</sup> Performance data ICFN <sup>2</sup> For other rpm there is a linear reduction in the air requirement. <sup>3</sup> EU Stage V only <sup>4</sup> Power ratings include generator power



# Maximum Power Output, Torque and Fuel Consumption

## 1B20

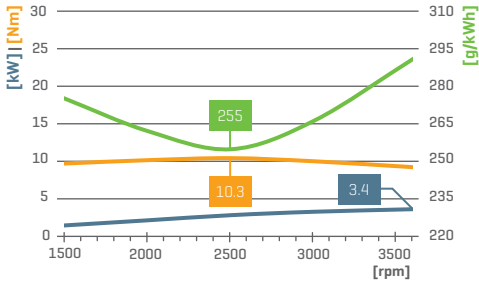

## 1B30E<sup>1,4</sup> | 1B30VE<sup>1,4</sup>

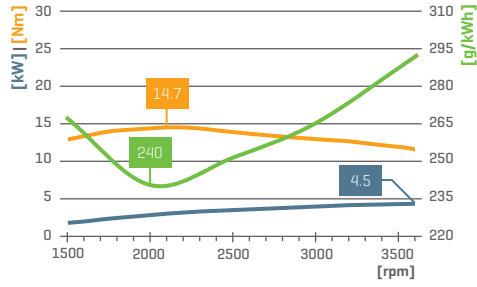

## 1B30

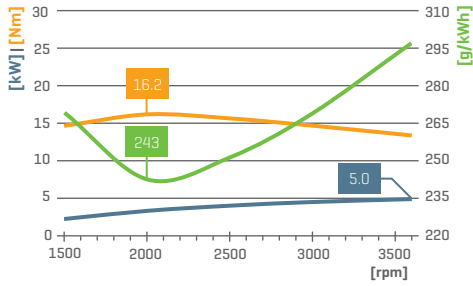

## 1B40

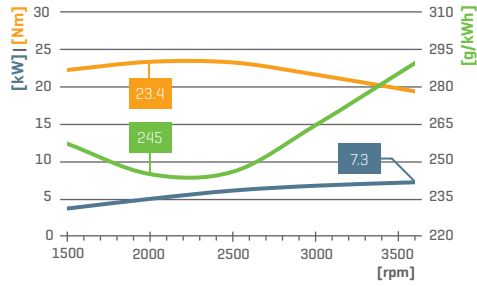

## 1B50E<sup>1,4</sup>

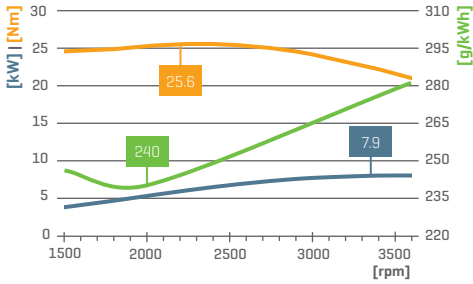

## 1B50

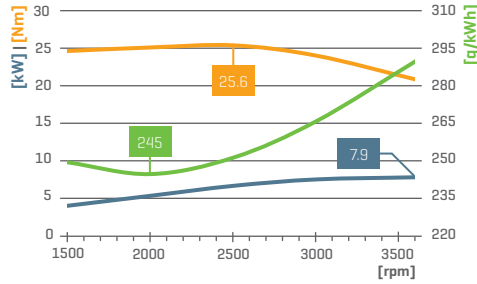

### Performance data

Performance data refer to Standard Reference Conditions of ISO 3046-1 (IFN): +25 °C (77 °F), 100 kPa, relative humidity 30 %. During running-in period the output increases by approx. 5 % which is taken into consideration at delivery. Power reduction acc. to ISO 3046-1. Standard values: Above 100 m ALT approx. 1 % per 100 m. Above 25 °C (77 °F) approx. 4 % per 10 °C (50 °F). The power taken from charging alternator also has to be added to the demand of power.

## Shaft Forms

### Selection of available shaft forms

	"7" Cyl. 3/4"	"2" <sup>6</sup>	"9" Cyl. <sup>5</sup>
Cylindrical with key way			
Conical			<b>X crank shaft</b> At crankshaft $J_{max} = 0.04 \text{ kgm}^2$
			<b>Universal</b>

<sup>4</sup>Power ratings include generator power <sup>5</sup>According to LEMA LES 1203-1991 <sup>6</sup>Only for mechanically controlled engine types

## Maintenance and Operating Points

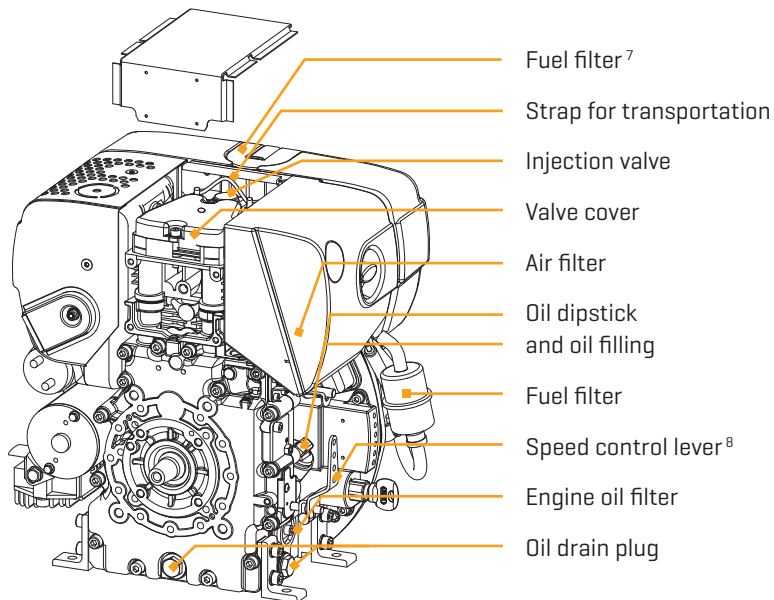

## Power-Take-off Points

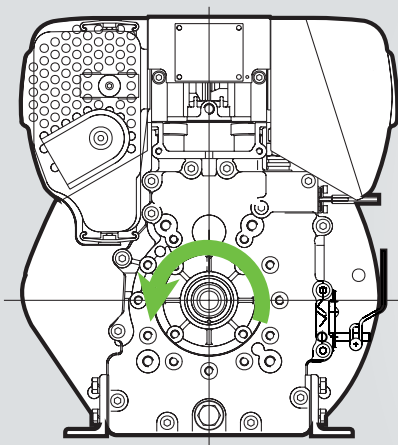

Power-take-off shaft, governor side, with max. engine speed, sense of rotation anti-clockwise.

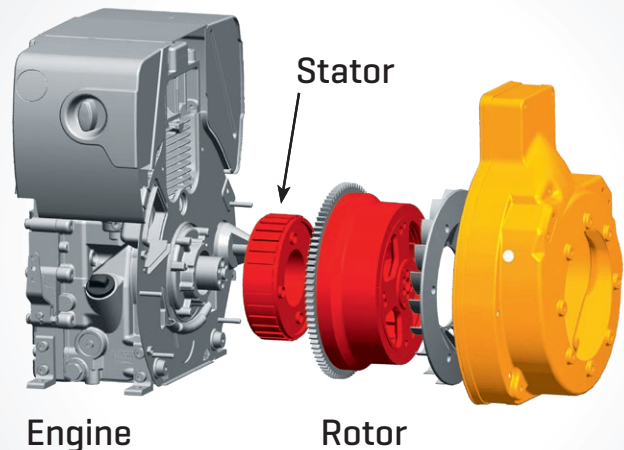

A permanent magnet alternator from 2 to 7 kW can be mounted on the flywheel side.

## Permissible Load on Power-Take-off Points

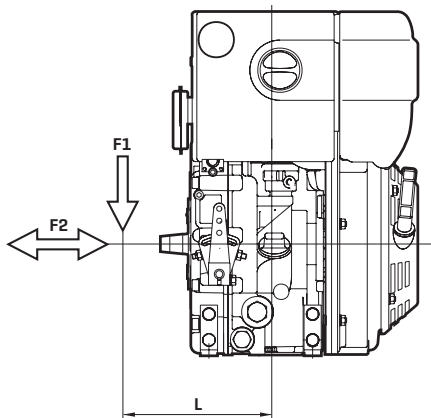

**1B20 / 1B30E / 1B30**

max. permissible radial force

$$F1 = \frac{60\,000}{L [\text{mm}] - 70} [\text{N}]$$

max. permissible axial force

$$F2 = 800 [\text{N}]$$

**1B40 / 1B50E / 1B50**

max. permissible radial force

$$F1 = \frac{62\,600}{L [\text{mm}] - 84} [\text{N}]$$

max. permissible axial force

$$F2 = 1200 [\text{N}]$$

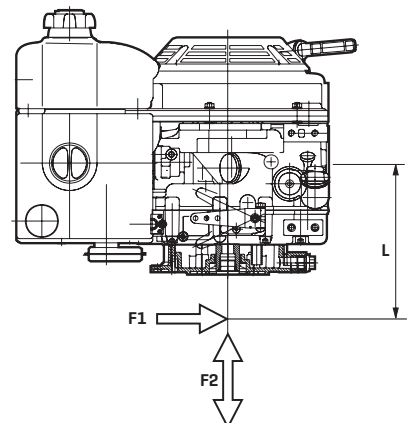

<sup>7</sup> Only for electronically controlled engines <sup>8</sup> Only for mechanically controlled engine types

# Dimensions [mm / in] and Inclinations<sup>9</sup> [°]

Spread at box dimensions ± 3 millimeters due to tolerance.  
 Drawings with detail and connection dimensions as PDF and DXF  
 can be found at [hatz.com](http://hatz.com).

## 1B20

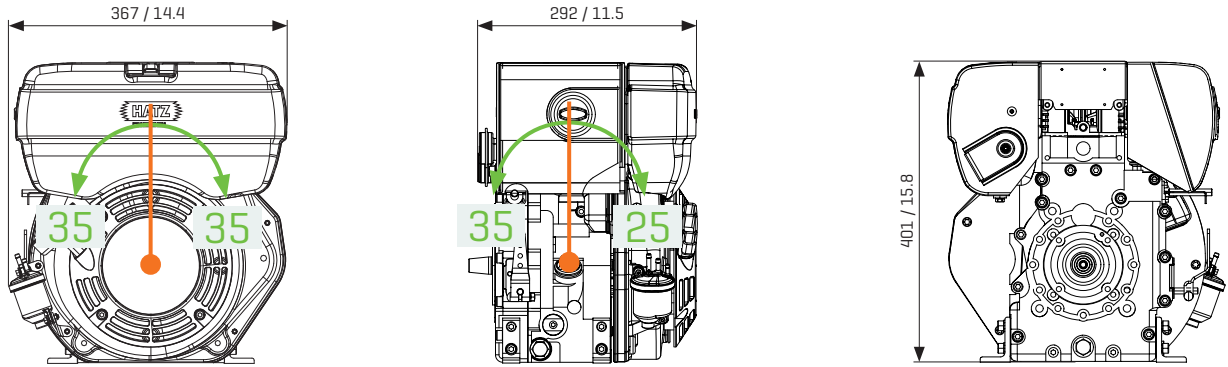

## 1B30E | 1B30

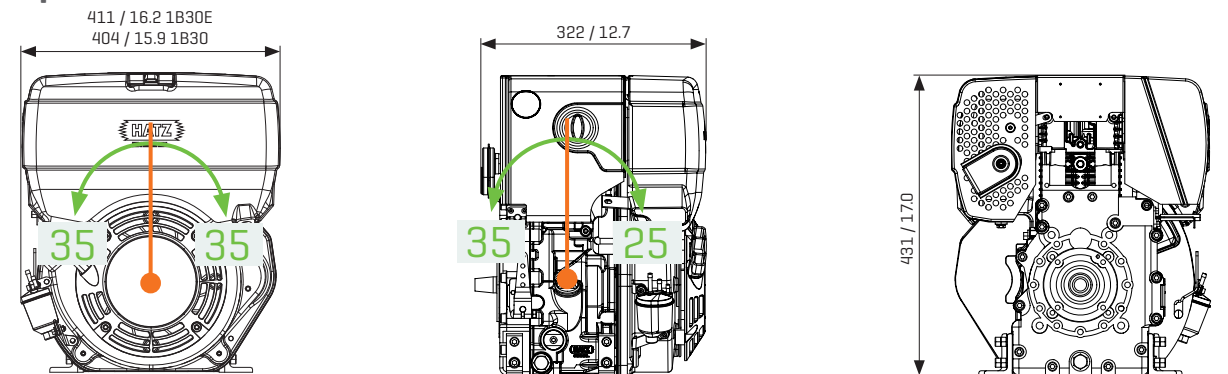

## 1B30VE

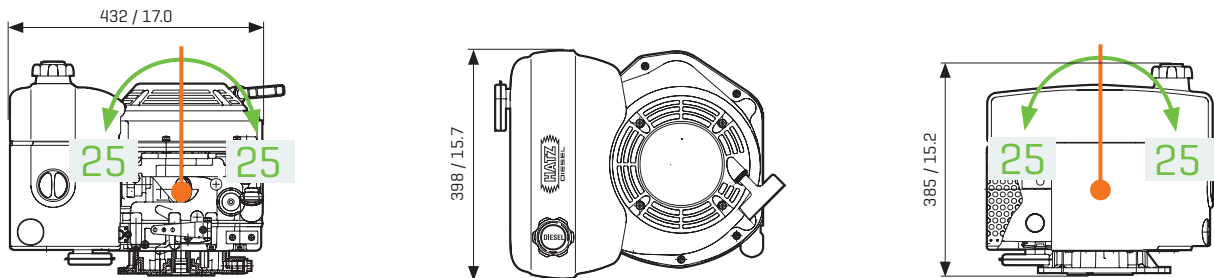

## 1B40 | 1B50E | 1B50

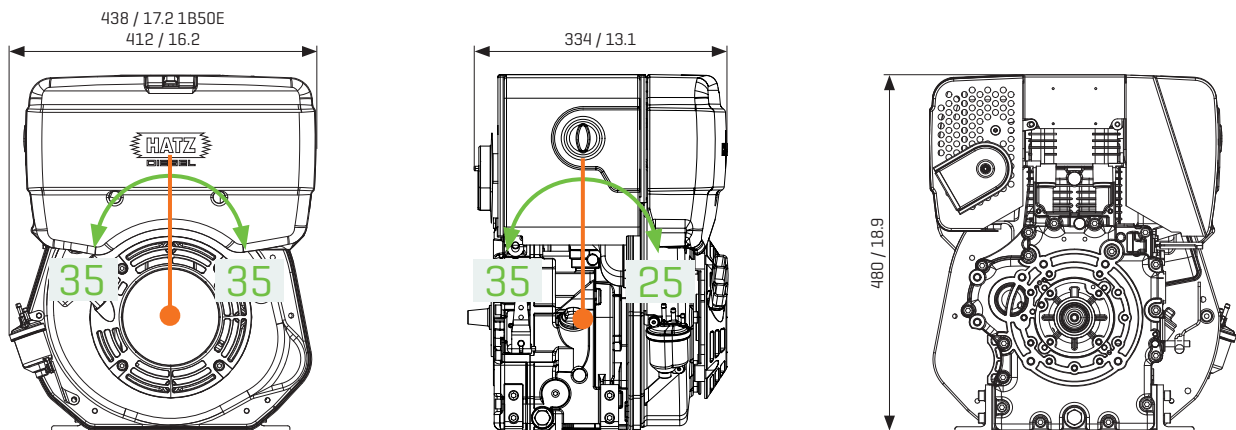

<sup>9</sup> Maximum permanent inclined positions

Hatz Diesel of North America, Inc.  
W229 N1645 Westwood Drive  
Waukesha WI 53186-1153  
United States of America  
Phone +1 [262] 544 0254  
info@hatznorthamerica.com  
hatznorthamerica.com



**CREATING  
POWER  
SOLUTIONS**

70257303 ENUS 02.23 Printed in US  
We reserve the right to make all changes that  
serve technical development.